

AIR MOTOR DRIVES

Important: Read and follow all instructions and **SAFETY PRECAUTIONS** before using this equipment. Retain for future reference.

QS-5003 air motor drive, 15-1 gear reduced for paint drums having built-in agitators. Includes air adjusting valve for 1/4" NPT(M) inlet.

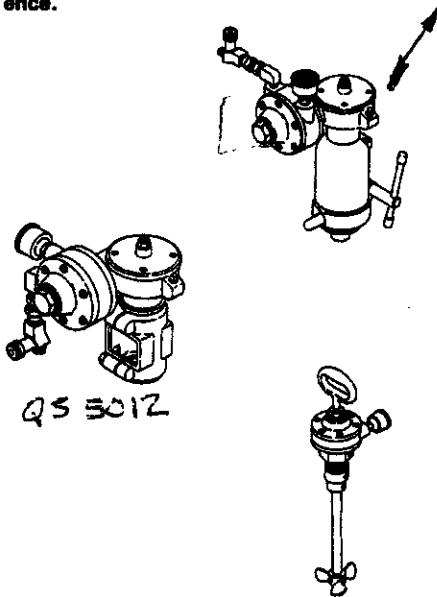

WARNING

High pressure can cause serious injury. Pressure is maintained in a pressure tank after the system has been shutdown. Before attempting removal of fill plug or cover, relieve tank pressure.

Pressure Relief Procedure

1. Turn off the main air supply to the tank.
2. Close air inlet valve located on tank air manifold.
3. Bleed off air in the tank by turning the air inlet valve handle counterclockwise. Wait until all the air has escaped through the valve before removing the pressure tank cover or fill plug.
4. Leave the air relief valve open until you have reinstalled the cover or fill plug.

INSTALLATION

QS-5012 Installation onto Pressure Tank with Agitator (Refer to Figure 3.)

1. Position agitator assembly over bearing assembly in lid until support (80) is fully seated on bearing assembly. It may be necessary to rotate the drive assembly in order to get the agitator assembly to engage in the gear box. Once engaged, again rotate the drive assembly until the air motor inlet and exhaust ports are aimed toward the rear of the tank. This will allow proper hookup of air hose and fittings to the tank regulator.
2. Tighten hex head cap screw (61).
3. Remove main air supply inlet valve from tank regulator and install service tee (67) in open port.
4. Connect tank air supply inlet valve to open end port of service tee (67). Install nipple (64) in open port of service tee.

5. If not already connected, install elbow (63) in air motor inlet port and upper nipple (64) in open elbow port. Connect air adjusting valve (65) to upper nipple. Connect hose assembly (66) between lower nipple (64) and air adjusting valve.

QMS-430 and QMG-416 Installation Into Pressure Tank (Refer to Figure 1.)

1. Follow pressure relief procedure before removing or loosening any tank lid components.
2. If not already separated, loosen propeller setscrew (32) and remove propeller from shaft.
3. Remove seal plug from paint tank lid and clean sealing surface around threaded port.
4. Make sure that the O-ring (26) is fully seated in groove of adapter (24). Install and tighten air motor adapter and shaft assembly into threaded center hole in tank lid.
5. Loosen setscrews (25) in adapter. Rotate air motor assembly until inlet port is aimed toward the rear of the tank to allow hookup of air hose and fittings to supply air inlet of tank regulator or service tee. Air hose provided for hookup is 10" long.
6. Retighten both setscrews (25).
7. Install propeller (31) on end of agitator shaft (30). Secure propeller with setscrew (32).
8. Remove main air supply inlet valve from tank regulator and install service tee (23). Install lower nipple (20) in open port of service tee.
9. Connect tank air supply inlet valve to end port of service tee (23). Install lower nipple (20) in open port of service tee.
10. If not already connected, install elbow (19) in air motor inlet port. Install upper nipple (20) in open port of elbow. Connect air adjusting valve (21) to upper nipple. Then, connect hose assembly (22) between air adjusting valve and lower nipple.

DESCRIPTION

The air motors covered in this service bulletin are designed to drive paint agitators when connected to a source of clean, dry, air pressure.

QS-5012 air motor drive, 15-1 gear reduced for pressure tank agitator. Includes air adjusting valve with necessary hose and fittings for hookup to tank regulator.

QMS-430 direct drive air motor and agitator assembly for 2 gal. stainless pressure tanks. Includes removable agitator and air motor with air shut off valve and necessary hose and fittings for hookup to tank regulator. Agitator supplied is suitable for use with halogenated hydrocarbon based solvents.

QMG-416 direct drive air motor and agitator assembly for 2 gal. galvanized pressure tanks. Includes removable agitator and air motor with air shut off valve and necessary hose and fittings for hookup to tank regulator. Agitator supplied is not suitable for use with halogenated hydrocarbon based solvents.

SAFETY PRECAUTIONS

This manual contains important information that all users should know and understand before using the equipment. This information relates to **USER SAFETY** and **PREVENTING EQUIPMENT PROBLEMS**. To help you recognize this information, we use the following terms to draw your attention to certain equipment labels and portions of this Service Bulletin. Please pay special attention to any label or information that is highlighted by one of these terms:



Important information to alert you to a situation that might cause serious injury if instructions are not followed.





Important information that tells how to prevent damage to equipment, or how to avoid a situation that might cause minor injury.

Note

Information that you should pay special attention to.



The following hazards may occur during the normal use of this equipment. Please read the following chart.

HAZARD	CAUSE	SAFEGUARDS
<p>Fire</p> 	<p>Solvents and coatings can be highly flammable or combustible, especially when sprayed.</p>	<ol style="list-style-type: none"> 1. Adequate exhaust must be provided to keep the air free of accumulations of flammable vapors. 2. Smoking must never be allowed in the spray area. 3. Fire extinguishing equipment must be present in the spray area.
<p>Explosion Hazard Tank Rupture</p> 	<p>Making changes to pressure tank will weaken it.</p>	<ol style="list-style-type: none"> 1. Never drill into, weld, or modify tank in any way. Carefully follow all instructions for motor drive installation. 2. Do not adjust, remove, or tamper with the safety valve. If replacement is necessary, use the same type and rating of valve.
<p>Explosion Hazard-</p> 	<p>Halogenated hydrocarbon solvents - Trichloroethane are not chemically compatible with the aluminum that might be used in many system components. The chemical reaction caused by these solvents reacting with aluminum can become violent and lead to an equipment explosion.</p>	<p>Aluminum is widely used in spray application equipment - such as material pumps, cups, regulators, valves, etc. Check all equipment items before use and make sure they can be used safely with these solvents. Read the label or data sheet for the material you intend to spray. If in doubt as to whether or not a coating or cleaning material is compatible, contact your material supplier. Any other type of solvent may be issued with aluminum equipment.</p>

QS-5003 Installation onto Drum Mounted Agitator (Refer to Figure 2)

1. Adapter (47) has two thread sizes: 1-1/2" NPS (M) on one end and 2" NPS (M) on the other end. Choose the proper thread size and place adapter over agitator shaft of drum and screw down securely.
2. Select proper driver shaft (46) and attach it to drive coupling assembly (48) with driver pin (45) and cotter pins (44). Place this assembly on shaft of drum agitator.
3. Slip air motor support (39) down over drive coupling assembly (48) and adapter (47).
4. Tighten air motor support (39) securely with screw assembly (43).
5. Install gear box (38) on air motor support (39), being sure to engage shaft of drive coupling assembly (48).
6. Tighten cap screw and hex nut (40 and 42).
7. Connect air supply line to air adjusting valve (52).

OPERATION

Before operating air motor, lubricate as covered in next section. Open valve to main air line; then slowly open air adjusting valve until agitator turns. To extend air motor life, adjust air pressure setting to run motor at about one revolution per second. The agitator should be run continuously while using the tank.

PREVENTIVE MAINTENANCE**Air Motor Lubrication**

Failure to properly lubricate the air motor will result in premature motor failure and will void warranty.

Lubricate air motor daily by adding 4 or 5 drops of SAE 10 weight oil into air inlet fitting. For convenience, an automatic oiler may be connected to the air inlet.

Periodically - Remove air adjusting valve and air strainer and flush motor with a clean suitable solvent. Remove trapped particles from screen in air inlet and clean air strainer felt.

Air Motor Gear Box Lubrication

Every 2 Days - Remove oil fill plug and check oil level. Proper oil level is indicated on outside of gear box housing. If oil level is low, add 140-weight SAE Gear Oil or a high quality worm gear lubricant. Replace pipe plug and tighten to 20 foot-pounds (27 N-m) of torque.

Note

Gear box oil is most easily drained just after motor operation, while oil is still warm.

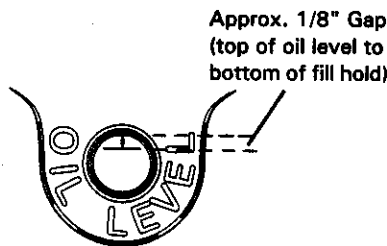
**Note**

Do not overfill. Overfilling may cause oil to leak out of vent cap on top of gear box.

After first 250 hours of operation, remove gear box and drain gear oil. Refill gear box with 140-Weight SAE Gear Oil or a high quality worm gear lubricant. Replace pipe plug and tighten to 20 foot-pounds (27 N-m) of torque.

6 Months or 2500 Operating Hours - Replace gear oil according to instructions above. Replace gear oil more often if environment causes oil to become contaminated during use.

REPLACEMENT OF PARTS

Removal of Air Motor and Gear Box (Refer to Figure 3 - typical assembly.)

1. Follow pressure relief procedure (Ref. Pg. 1) before removing or loosening any components.
2. Turn off valve to main air supply and disconnect air adjusting valve (65) at nipple (64).
3. Loosen upper cap screw (61) and remove air motor and gear box assembly from support (60).

Air Motor (Refer to Figure 4)

Holes must be drilled for new dowel pins (72) after assembling front plate (77) on new body (76) for alignment of parts.

Do not pry front plate (77) or end plate (71) from air motor body (76) with a screw driver; this will dent the surface of the body and plates causing leaks. A puller tool should be used to remove the plate from the motor body while maintaining the position of the shaft.

Always install new gaskets (73) when reassembling air motor.

Assemble the end plates to the body using an arbor press with a pusher acting on both races of the bearing while rigidly supporting the opposite (drive) end of the shaft.

Gear Box (Refer fo Figure 5)

1. Remove oil fill plug (88) or cover plate (84) and drain gear box lubricant.
2. Remove setscrews (91) and remove gear box from air motor.
3. Disassembly gear box per exploded view, Figure 5. Discard gaskets (87 and 92). Do not remove oil seal (90) unless leakage or seal damage is indicated.
4. If oil seal (90) was removed, inspect seal seating bore in housing (89). Remove any burrs or contaminants from seal seating bore. Burrs or contaminants could distort new oil seal during installation.
5. Inspect gear and shaft assembly (86) for wear grooves, burrs, or contamination of seal seating area. If seal seating area is damaged, shaft must be repaired or replaced.
6. Inspect all other parts for wear spots, chipping, or other damage. Replace damaged or worn parts.
7. If oil seal (90) is being replaced, inspect new seal for damage before installing. Use arbor press to install seal. Press fixture diameter must be close fit with gear box bore diameter to avoid damage to seal. Install with inner casing and sealing lip toward bottom of bore. Drive seal squarely into bore to avoid warping. Check that seal is fully seated all around at bottom of bore.
8. Reassemble gear box per exploded view. Install new gaskets (87 and 92). Just prior to assembling gear box with air motor, apply a small dab of thread locking compound (81) to threads of setscrews (91). Connect motor and gear box and torque setscrews (91) to 60 inch-pounds (6.8 N-m), minimum. Refill gear box per gear box lubrication instructions.

AIR MOTOR DRIVE SERVICE CHECKS		
CONDITION	CAUSE	CORRECTION
A. Air motor sluggish or inefficient.	<ol style="list-style-type: none"> 1. Air motor needs lubrication or cleaning. 2. Motor vanes need replacing or contaminants present in motor chamber, Fig. 4. 3. Low oil level in gear box, Figure 5. 4. Gear and shaft assembly (86) and/or worm gear (93) worn, Figure 5. 5. Air motor bearing (68 or 79) worn, Figure 4. 	<ol style="list-style-type: none"> 1. Lubricate (see "Air Motor Lubrication" section). Disassemble and clean per parts replacement instructions. 2. Disassemble, clean motor per parts replacement instructions. Replace worn vanes. 3. Add oil per lubrication instructions, Figure 5. 4. Replace worn parts per parts replacement instructions. 5. Replace bearings per parts replacement instructions.
B. Oil leakage from gear box.	<ol style="list-style-type: none"> 1. Seal (90, Figure 5) worn. 	<ol style="list-style-type: none"> 1. Replace seal per parts replacement instructions.

**Direct Drive Air Motor and Agitator Assemblies QMS-430 (Stainless Steel Shaft)
QMG-416 (Plain Steel Shaft)**

Parts List for Figure 1

Ref. No.	Replacement Part No.	Description	Ind. Parts Req'd.
1	QN-97	Carrying Handle	1
2	QMG-18	End Cap	1
3*†	---	End Cap Gasket	1
4 †	PT-58	Bearing	2
5 †	Purchase Locally	Machine Screw	12
	1/4-28 x 1/2		
6 †	---	Front Plate	1
7*†	PT-59-K10	End Plate Gasket Kit	2
	(Kit of 10)		
8 †	QS-189-1-K10	Dowel Pin (Kit of 10)	4
9 †	---	Body	1
10*	---	Vane	4
11 †	PT-57	Rotor Assy. for QMG-416	1
	---	Rotor Assy. for QMS-430	1
		(Not available separately, order QMS-428 Air Motor	
		End Plate	1
12 †	---	Seal	1
13 †	PT-56	Strainer Cup	1
14	---	Screen	2
15 ♦	---	Felt	1
17	---	Strainer Body	1
18 †	350-401	Air Strainer	1
19*	Purchase Locally	Street Elbow 1/4" (M)	1
		x 1/4" (F) NPT	
20	H-2008	Nipple 1/4" NPS (M)	2
		1/4" NPT (M)	
21	HAV-500	Air Adjusting Valve, 1/4" NPS (M) x 1/4" NPS (F)	1

Ref. No.	Replacement Part No.	Description	Ind. Parts Req'd.
22	HA-57011	Hose Assembly	1
23	Purchase Locally	Service Tee 1/4" Galv.	1
24#	---	Adapter	1
25#	---	Setscrew	2
		(1/4-20 x 1/4")	
26	SSG-8184-K2	O-Ring (Kit of 2)	1
27	KK-5041	Shaft Seal Kit	1
28#	---	Shaft Coupling	1
29#	Purchase Locally	Setscrew	2
		(1/4-20 x 1/4" s.s.)	
30	QMS-73	Agitator Shaft for QMS-430	1
	QMG-56	Agitator Shaft for QMG-416	1
31	QMS-448	Propeller Kit (includes 31A & 32)	1
31A	---	Agitator Propeller	1
32	Purchase Locally	Setscrew	1
		(1/4-20 x 3/8" s.s.)	
32A	KK-4991	Agitator Kit for QMS-430 (Includes Item Nos. 24, 25, 28, 29)	1
	KK-4990	Agitator Kit for QMG-416 (Includes Item Nos. 24, 25, 28, 29)	1

* Parts included in KK-5001-1 Air Motor Repair Kit.

When replacing either Ref. Nos. 24, 25 or 28 & 29, you must order Ref. No. 32A, KK-4991 for QMS Models or KK-4990 for QMG Models. The kit includes necessary parts.

♦ Ref. No. (15) 2 ea. and Ref. No. (16) 4 ea. are included in KK-5006 Strainer Screen and Felt Kit.

† Parts included in PT-410 Air Motor Assembly.

Figure 2 QS-5003 Gear Drive Air Motor

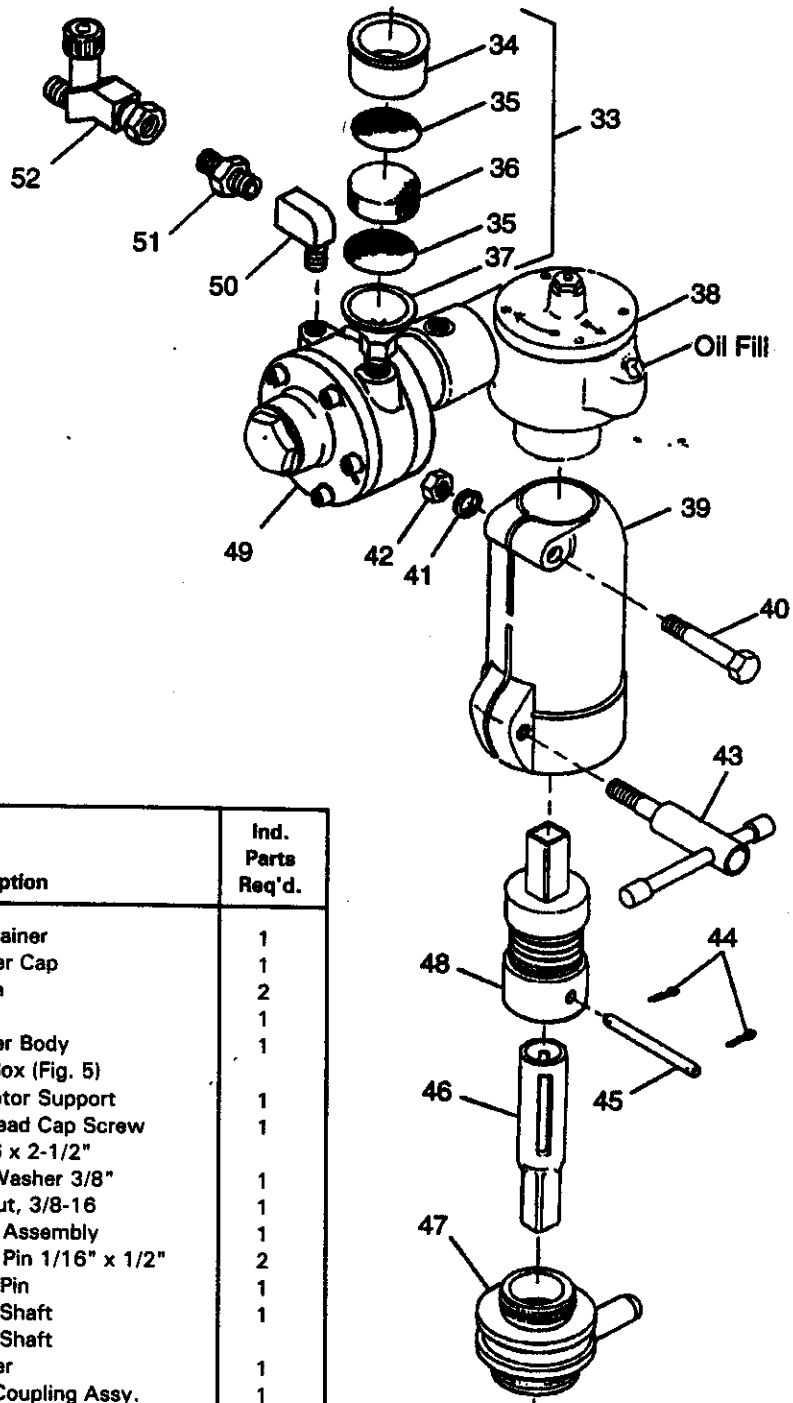

Parts List for Figure 2

Ref. No.	Replacement Part No.	Description	Ind. Parts Req'd.
33	350-401	Air Strainer	1
34	---	Strainer Cap	1
35 +	---	Screen	2
36* +	---	Felt	1
37	---	Strainer Body	1
38	---	Gear Box (Fig. 5)	1
39	QS-238	Air Motor Support	1
40	Purchase Locally	Hex Head Cap Screw 3/8-16 x 2-1/2"	1
41	Purchase Locally	Lock Washer 3/8"	1
42	Purchase Locally	Hex Nut, 3/8-16	1
43	QS-456	Screw Assembly	1
44	Purchase Locally	Cotter Pin 1/16" x 1/2"	2
45	QS-237	Driver Pin	1
46	QS-240 1/2"	Driver Shaft	1
	QS-242 7/16"	Driver Shaft	1
47	QS-457	Adapter	1
48	QS-455	Drive Coupling Assy.	1
49	---	Air Motor, Fig. 4)	1
50	Purchase Locally	Street Elbow, 1/4" (M) x 1/4" (F) NPT Galv.	1
51	H-2008	Nipple, 1/4" NPS (M) x 1/4" NPT (M)	1
52	HAV-500	Air Adjusting Valve 1/4" NPS (M) x 1/4" NPS (F)	1

* Included in KK-5001-1 Air Motor Repair Kit. See Page 8 for additional parts included in kit.

+ Ref. No. (35) 2 ea. and Ref. No. (36) 4 ea. included in KK-5008 Strainer Screen & Felt Kit.

Figure 3 QS-5012 Gear Drive Air Motor

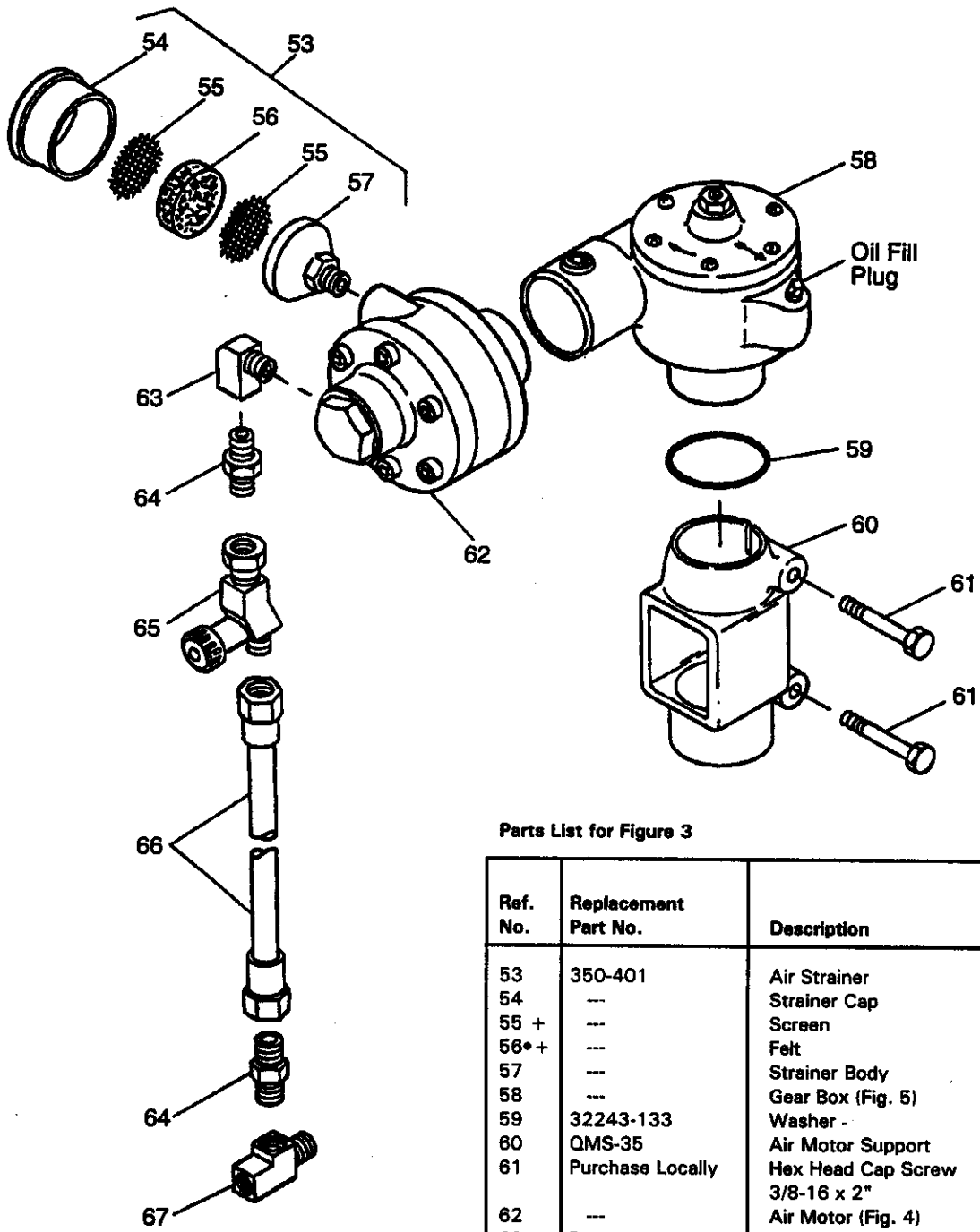

Parts List for Figure 3

Ref. No.	Replacement Part No.	Description	Ind. Parts Req'd.
53	350-401	Air Strainer	1
54	---	Strainer Cap	1
55 +	---	Screen	2
56* +	---	Felt	1
57	---	Strainer Body	1
58	---	Gear Box (Fig. 5)	1
59	32243-133	Washer	1
60	QMS-35	Air Motor Support	1
61	Purchase Locally	Hex Head Cap Screw 3/8-16 x 2"	2
62	---	Air Motor (Fig. 4)	1
63	Purchase Locally	Street Elbow 1/4" (M) 1/4" NPT (F)	1
64	H-2008	Nipple 1/4" NPS (M) 1/4" NPT (M)	1
65	HAV-500	Air Adjusting Valve 1/4" NPS (F) x 1/4" NPS (M)	1
66	HA-57011	Hose Assembly	1
67	Purchase Locally	Service Tee 1/4" Galv.	1

* Included in KK-5001-1 Air Motor Repair Kit. See Page 8 for additional parts included in kit.

+ Ref. No. (55) 2 ea. and Ref. No. (56) 4 ea. included in KK-5006 Strainer Screen and Felt Kit.

Figure 4 QS-4016 Air Motor
(for QS-5003 and QS-5012)

Parts List for Figure 4

Ref. No.	Replacement Part No.	Description	Ind. Parts Req'd.
68	QS-336	Oil Seal	1
69	QS-197	Bearing	1
70	Purchase Locality	Machine Screw, 1/4-28 X 1/2	12
71	QS-334	End Plate	1
72	QS-189-1-K10	Dowel Pin (Kit of 10)	4
73*	PT-59-K10	End Plate Gasket Kit (Kit of 10)	2
74*	---	Vane	4
75	QS-442	Rotor and Shaft Assy.	1
76	QS-335	Body	1
77	QS-333	Front Plate	1
78*	---	End Cap Gasket	1
79	PT-58	Bearing	1
80	QS-190	End Cap	1

* Parts available in KK-5001-1 Air Motor Repair Kit.

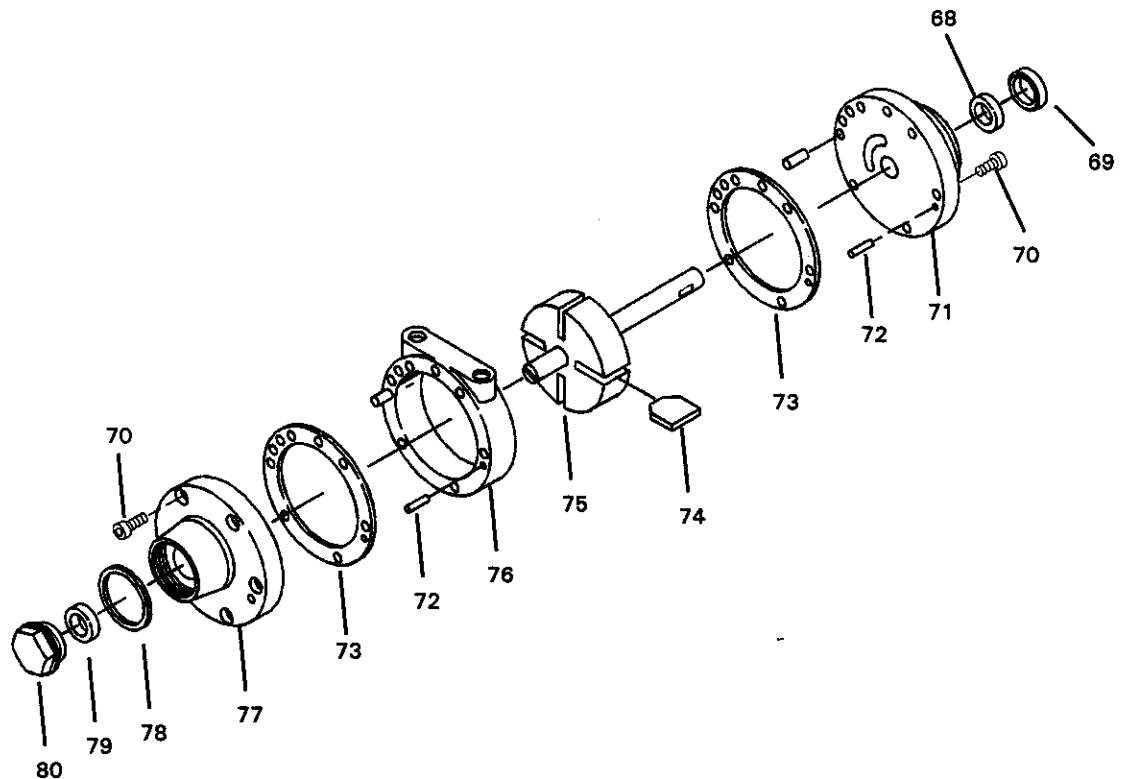
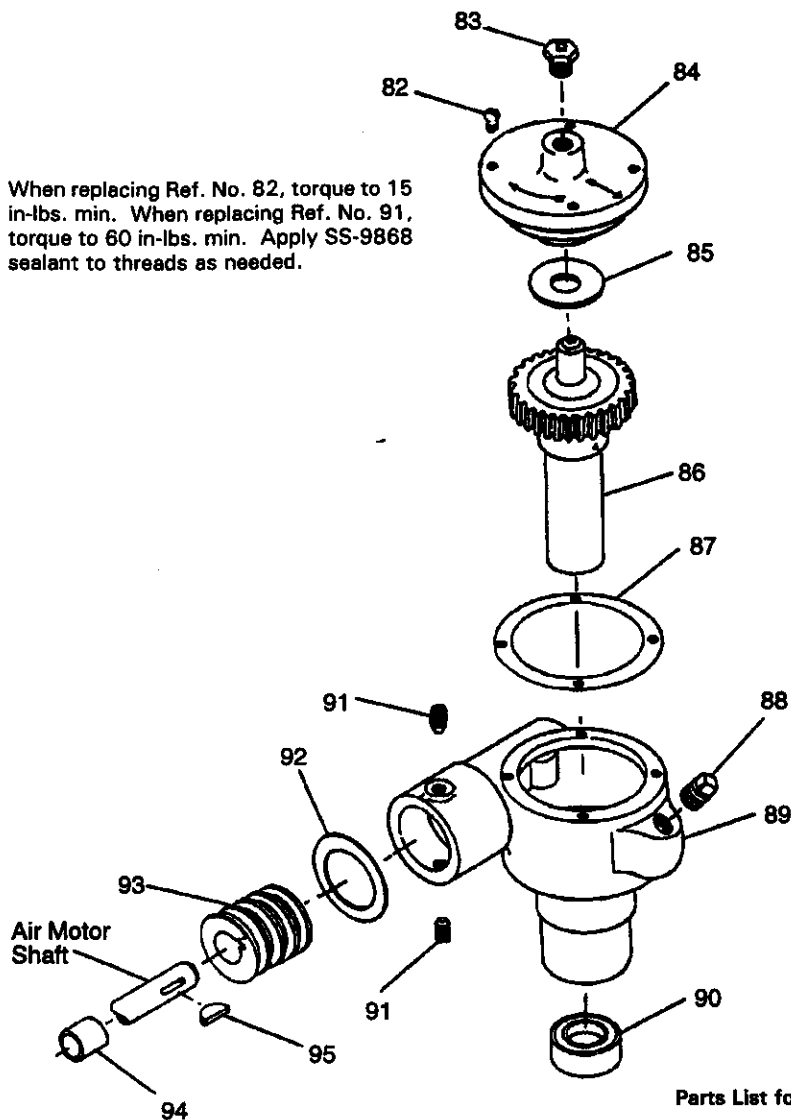

Figure 5 Gear Box Assembly

When replacing Ref. No. 82, torque to 15 in-lbs. min. When replacing Ref. No. 91, torque to 60 in-lbs. min. Apply SS-9868 sealant to threads as needed.



Parts List for Figure 5

Ref. No.	Replacement Part No.	Description	Ind. Parts Req'd.
81	---	Thread Locking Compound, not shown	
82 •	---	Fillister Head Machine Screw 10-24 x 5/8"	4
83	QS-108	Pressure Relief Fitting	1
84	QS-37-1	Cover Plate	1
85 •	---	Washer	1
86	QS-416-1	Gear & Shaft Assy.	1
87 •	---	Gasket	1
88	Purchase Locally	Pipe Plug 1/4", Galvanized	1
89	QS-36-1	Housing	1
90 •	---	Oil Seal	1
91 •	---	Cup Point Setscrew 5/16-18 x 3/8"	2
92 •	---	Gasket	1
93	QS-59	Worm Gear	1
94 •	---	Spacer	1
95 •	---	Key, No. 5, 5/8" x 1/8"	1

• Parts included in KK-5010 Gear Box Kit.